

New Insights into Calender Barring Prevention

Stuart Shelley
Sheet Dynamics, Ltd.
8686 Long Lane
Cincinnati, OH 45231

Jake Zwart
LSZ Paper Tech, Inc.
1075 Milborough Line
R.R. 1 Millgrove, ON L0R 1V0

André Fournier
Abitibi-Consolidated, Inc.
1100 Melacon St.
Alma, PQ G8B-5W2

Abstract

To gain an understanding of the physics of calender barring, a non-linear model of the dynamics of the barring process was developed. It incorporates an enhanced model of the paper in the nip using an inverted form of the calendaring equation and the latest research in the difference between the paper strain in the nip and the relaxed paper strain. Simulations were run on the computer model and were compared with observed phenomena. This gave insight into the barring mechanism not previously known. The characteristics of the paper feedback mechanism were examined in detail. The interaction of the paper feedback mechanism with corrugated roll wear and forced excitation are explained.

Keywords

calender, stack, barring, stack, dynamics, calendaring equation, modal analysis, caliper, offsets, rolls, stiffness, vibration, feedback,

Introduction

Calender barring is a caliper variation causing a resultant paper quality loss. It results in increased maintenance costs and effort from frequent changes of calender rolls. It can occur with or without the corrugation of calender rolls. This problem has baffled many paper mills for years. Despite extensive research it remains a poorly understood phenomena.

Our goal has been to develop a thorough understanding of the physics associated with calender barring, which would lead to a feasible and definitive solution.

Existing literature was reviewed. Vibration studies and comprehensive barring studies were performed in a mill setting. This was followed by the development of a computer model of the barring phenomenon to match the measured data. The model was required to predict the range of barring symptoms observed at all mills and

reported in the literature. This paper presents a brief overview of the current understanding of the calender barring problem resulting from this modeling effort.

Calender Barring Background

Calender barring has been studied extensively over the past thirty years [1,2,3,4,5,6,7,8,9,10,11,12,13] yet a consensus understanding of the problem has not been reported.. A common understanding eludes the paper making industry because barring is an extremely complex phenomenon, exhibiting a multitude of different and sometimes, seemingly contradictory symptoms.

The parameters influencing barring include:

- roll diameter
- roll offset
- number of rolls in the stack
- roll grinding practices
- nip load
- paper moisture content
- roll temperature
- machine speed
- basis weight
- breaker stack open or closed
- grit content of paper
- press section vibrations
- flow instabilities at wet end
- use of swimming or cc rolls
- nip relief
- external vibration sources.

This is a large number of parameters which partly explains the confusion surrounding calender barring.

Subtle changes in any of these parameters can often eliminate or initiate barring, or change the amplitude and frequency at which it occurs. Much of the work conducted on calender barring has been focused on immediate solutions, attempting to identify straightforward causes which can be addressed to cure

the problem. Since it is nearly impossible to isolate and identify the effects of the influencing parameters independently, it is easy to draw false conclusions regarding causes and possible solutions.

Stack dynamics

The rolls in a calender stack behave as masses connected by springs. The effective stiffness results from the paper being compressed in the nip. The stack has resonant frequencies at which it is particularly susceptible to vibration excitation. In the neighborhood of these resonant frequencies the stack vibrates in a particular shape. This implies a displacement and phase relationship between the rolls. Self-excited vibration occurs at or near resonant frequencies because of the predisposition of the stack to vibrate at these frequencies.

There is general agreement [14] that there are two main mechanisms which cause barring in calender stacks. Both are self excited vibrations. The first is caused by regenerative feedback between nips through variation in paper caliper. The second is regenerative wear of calender rolls causing corrugation of the roll. Paper caliper induced feedback can occur instantaneously if the right conditions are in place while it takes time to wear corrugations in a calender roll.

Paper Feedback Mechanism

Any infinitesimally small deviation in paper bulk or basis weight entering a nip will cause a variation in nip load which will excite the stack. Because the stack vibrates in specific mode shapes, this vibration causes the entire stack to vibrate, resulting in the nip gaps between all the rolls to vary dynamically. Under certain conditions of stack configuration and operating parameters, the stack will continue to vibrate without any other apparent source. In this case the preceding nip imparts a variation in paper bulk. When this paper bulk variation enters the next nip it reinforces the stack vibration, causing self sustained vibration and barred paper.

Regenerative Roll Wear Mechanism

The second mechanism is regenerative roll wear. This is the same regenerative wear mechanism that has been studied in relation to machine tool grinding and

turning processes [15]. Washboards on road surfaces or railway tracks are caused by this mechanism.

All other conditions being equal, calender roll wear is proportional to nip load. Any microscopic roll surface irregularity (a high spot or a low spot) will result in a variation in nip force when the irregularity enters the nip. The variation in nip force causes vibration of the rolls in the stack which excite the stack modes. This in turn causes a variation in the nip load. Under certain stack conditions there are frequencies at which the stack vibration resulting from the irregularity passing through the nip will cause the nip load to vary such that, when the irregularity re-enters the nip, the wear process causes it to grow. This regenerative wear process is only stable for an integer number of corrugations occurring around the circumference of the roll.

Stack Simulation Model with Paper Feedback Model

Figure 1 shows a Simulink™ block diagram model of a calender stack. This model predicts barring due to the paper feedback mechanism. The most challenging task in generating this model was developing a model of in-nip paper characteristics that predict realistic caliper variations and dynamic nip loads as a function of roll vibration. The "Calender Nip" blocks accomplish this utilizing an inverted form of the calendaring equation and research results of Browne [16] which relate in-nip to permanent paper strain. The nip blocks calculate instantaneous exiting paper caliper and nip load based on instantaneous entrance paper caliper and nip gap.

The "Delay Calculation" and "Delay" blocks implement the paper transport delay between successive nips. They are a function of machine speed, roll diameter and roll offset. The "Roll" blocks model the roll mass characteristics, apply linear or quadratic viscous damping forces, and calculate the roll position (nip gap) based on the nip loads generated in "Calender Nip" blocks.

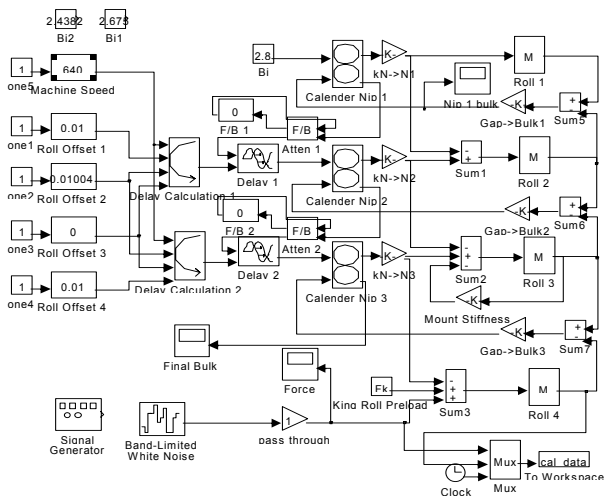

Figure 1: Simulation Model Block Diagram

During operation of the simulation model both the machine speed and the offset of each roll can be adjusted to determine the effect of these parameters on barring behavior. Each of the blocks to the left of the system block diagram, labeled "Machine Speed" and "Roll Offset", expand into a slider bar control to adjust these parameters.

Illustrative Results of Initial Simulation

The simulation may be used to explore the effect of varying most calender stack and paper furnish parameters. The machine speed, roll offset, roll mass, roll diameter, number of rolls, and which roll is attached to the stack frame may be changed. The effects of paper characteristics are handled through the

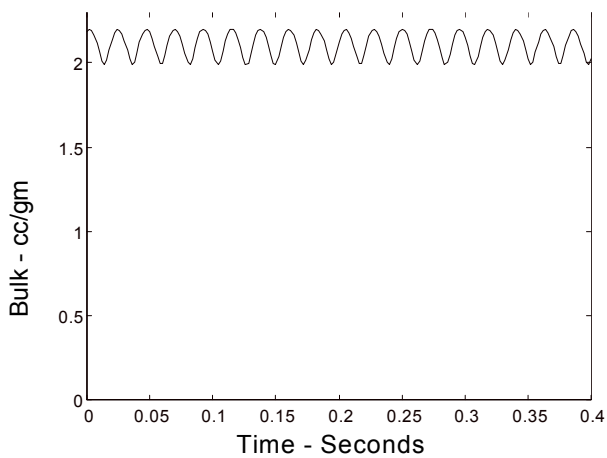

Figure 2: Caliper Variation - 655 m/min

calendering equation parameters. The effects of two readily controlled parameters, machine speed and roll offset, are illustrated below.

Effect of Change in Machine Speed on Barring

The simulation model was run for a typical four roll calender stack configuration. The values used for the paper calendering equation parameters were for TMP furnish.

The calendering equation coefficients describing the paper properties were not tuned to exhibit the same resonant frequencies as the target calender stack in this phase of the project. Because of this the barring frequencies from the simulation do not match the frequencies observed on the calender stack.

The sheet entering the first nip has a bulk of 2.8 cc/gm with no bulk variation. Any barring observed is due entirely to self excited vibration, with no effects attributable to variation in sheet properties entering the first nip.

Figure 2 and Figure 3 show the time and frequency plots of paper caliper variation for the first condition. The machine is running at 655 m/min with offsets of 0.010, 0.000, 0.010 and 0.010 meters. For these conditions barring is occurring primarily at 220 Hertz. When the machine speed is increased to 675 m/min, shown in Figures 4 and Figure 5, barring disappears completely and the sheet exiting the calender stack has no variation in caliper. The caliper spectrum in Figure 5 is not visible when plotted with the same y-axis scale as Figure 3. Figure 6 and Figure 7 show the barring

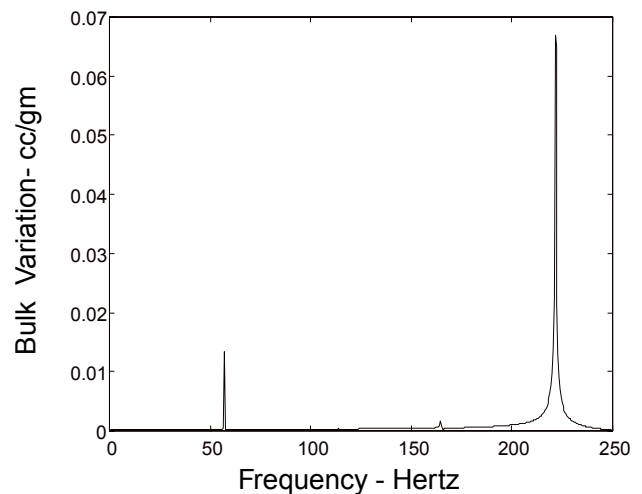

Figure 3: Caliper Spectrum - 655 m/min

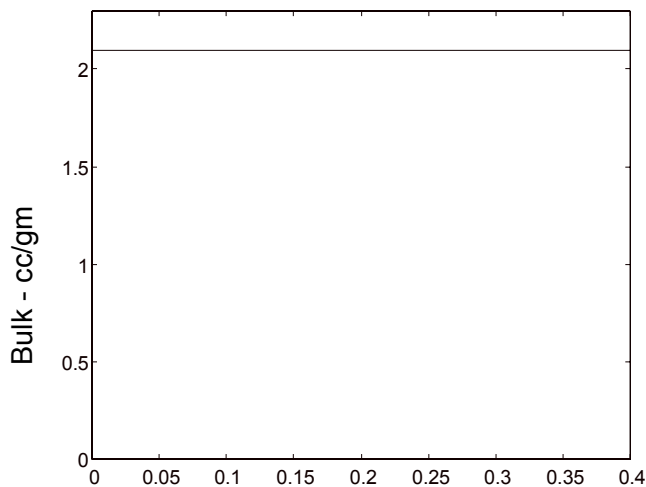

Figure 4: Caliper Variation - 675 m/min

behavior with the machine speed increased to 685 m/min. Barring is occurring at a lower frequency of approximately 175 Hertz.

Effect of Roll Offset on Barring Behavior

With the machine operating at 655 m/min the barring is shown in Figure 2 and Figure 3. When the offset of roll three is changed to -0.010 meters from 0.010, the barring is totally eliminated and there is no noticeable caliper variation. The results are identical to Figure 4 and Figure 5.

Effect of Regenerative Feedback on Stack Dynamics

Barring caused by regenerative caliper variation

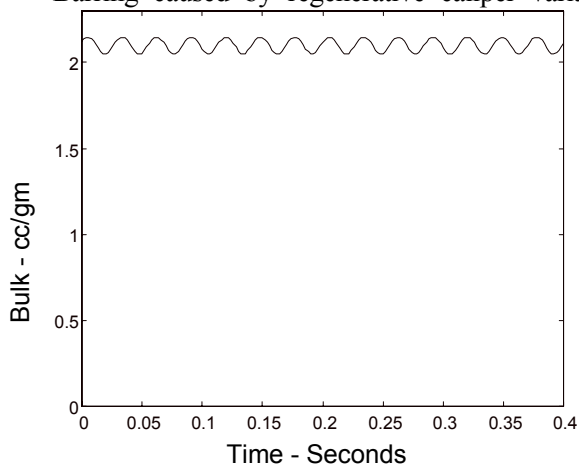

Figure 6: Paper Caliper Variation - 685 m/min

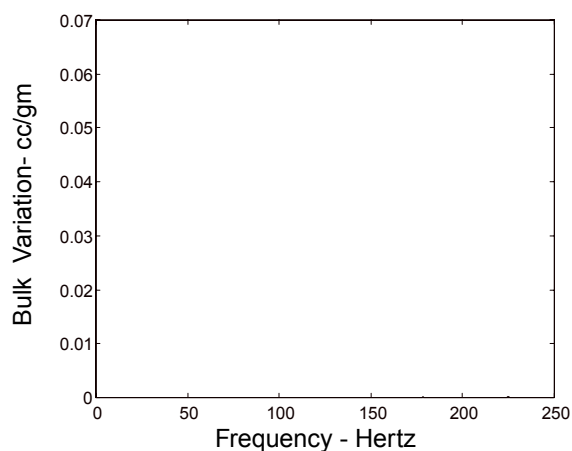

Figure 5: Caliper Spectrum - 675 m/min

feedback has been looked at as an "all or nothing" phenomenon. In other words, if the stack is not experiencing paper barring due to regenerative feedback, regenerative feedback was not considered to have an effect. The simulation work performed indicates that this is not the case at all.

The dynamic characteristics of a system are normally plotted with frequency response functions (FRFs). FRFs are a measure of the magnitude and phase of the vibration response of a point on a system due to a dynamic force applied at the same or another point on the system. To determine the effect of regenerative feedback on calender stack dynamics, the simulation model was run at a condition where barring was not occurring. At this condition the FRF was

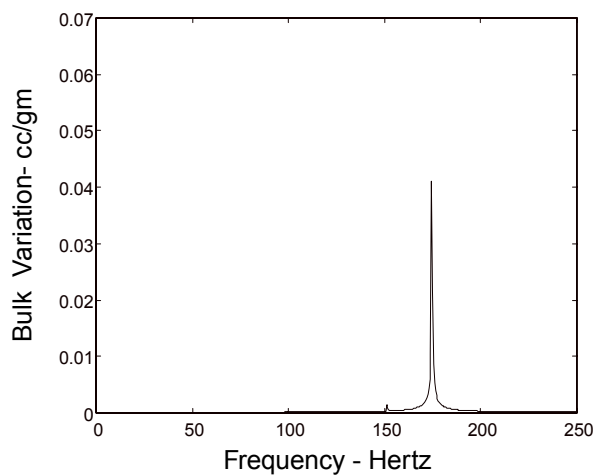
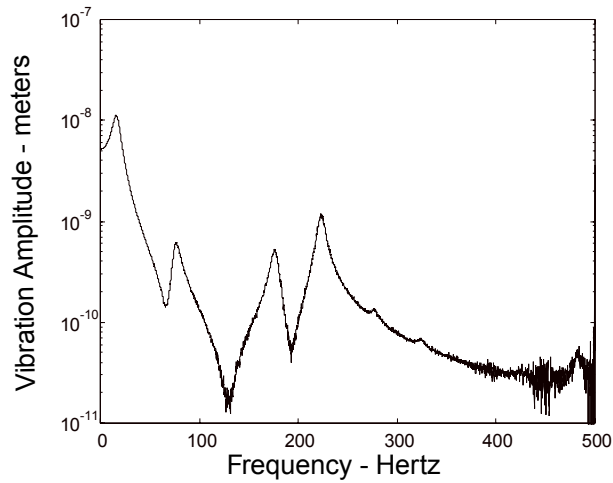

Figure 7: Caliper Spectrum - 685 m/min



• Figure 8 Stack Dynamics Without Effect of Regenerative Feedback

calculated.

Initially, the feedback mechanism was eliminated by artificially removing any caliper variation in the paper between successive nips. The resulting FRF is shown in Figure 8. The four peaks evident in the FRF are the four modal resonances of the calender stack.

Figure 9 is the same FRF with the effects of regenerative paper feedback added. A number of feedback resonances are superimposed on the FRF without paper feedback. The amplitude of the FRF at these frequencies (note the logarithmic amplitude scale) is an order of magnitude higher than the open loop response shown in Figure 8.

The implication of these feedback resonances is significant in two respects. First, the regenerative roll wear which causes roll corrugations is a function of the dynamics of the calender stack. The paper feedback resonances undoubtedly exacerbate the corrugation wear process. This interaction between the two barring mechanisms has not previously been considered in the literature.

Second, the feedback resonances make the system extremely susceptible to external excitation that may occur at these frequencies. For instance, if there is vibration from a dryer gear mesh frequency entering the calender stack at a frequency matching one of the feedback resonances, the stack will be excited and paper barring may occur. Since the feedback resonances are extremely lightly damped and narrow in frequency, very small changes in the frequency of the

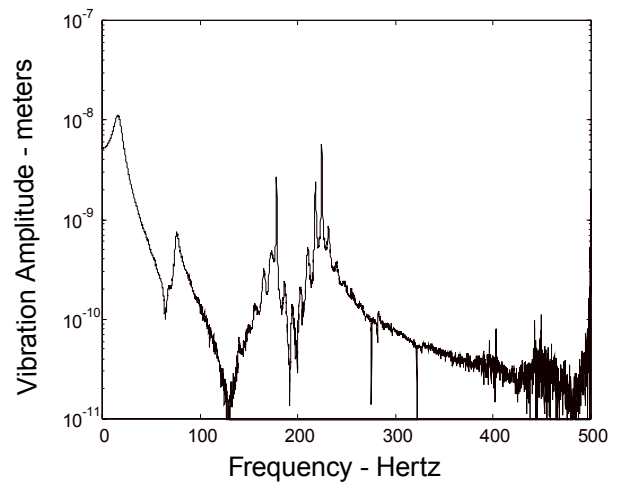

• Figure 9 Stack Dynamics With Effect of Regenerative Feedback

disturbance or of the resonance will cause the barring to stop or start.

Solutions Which May be Investigated Using the Simulation Model

The simulation model must be tuned to match the characteristics of the calender stack and paper furnish of interest. Calendering equation parameters and the relationship between in-nip and permanent paper strain must be determined for the paper furnish of interest. An experimental modal analysis of the stack must be conducted while the machine is running in order to accurately determine the calender stack natural frequencies.

Once the computer model accurately reflects the physical reality of the calender stack it may be utilized to evaluate a wide range of possible solutions to the calender barring problem.

Various stack configurations can be investigated, evaluating different combinations of roll offset, number of rolls, roll diameters, and the position of rolls in the stack in order to arrive at a configuration which is most resistant to barring.

Since barring is highly dependent on machine operating parameters, various schemes to tune the operating parameters to avoid barring can be investigated. Both stack vibration and/or roll corrugations can be monitored to determine if barring is regenerative (increasing) or destructive (decreasing). Then the machine speed, for instance, can be changed

slightly to prevent regenerative roll wear from occurring.

More innovative solutions such as adding passive dampers between roll bearing housings, on-line offset adjustment, or active vibration control may also be investigated using this model.

Conclusions

A time domain computer model of a calender stack, incorporating a unique paper feedback mechanism, has been developed. It predicts observed barring symptoms. Work is progressing to tune the model and evaluate potential solutions to barring.

References

- ¹ **Bercel, E.**, "Normal modes of vibration of a closed-frame calender stack", TAPPI, November 1979, 62(11) pp 93-96
- ² **Bradford, R.A.**, and Emmanuel, A., "Calender Vibration Behavior at a Large Newsprint Machine", Appita, 41(3) May 1988, pp 224-230
- ³ **Cotgrove, L.B.**, "Calender Barring - Causes and Cures", Pulp and Paper Mill Equipment, Feb 1988
- ⁴ **Cuffey, W.H.**, "Newsprint calender vibration as it affects machine-direction caliper uniformity" Pulp and Paper Mag. Can., 1963, 64(9), T379-T388
- ⁵ **Emmanuel, A.**, "Some experiences with calender barring on a newsprint machine and diagnosis of roll corrugations", July 1985, Appita (38)4: 269-274
- ⁶ **Howe, B.I.** and Cosgrove, J.C., "Calender stack barring on newsprint machines", Pulp and Paper Mag. Can., 1963, 64(6) T259-T274
- ⁷ **Matumaki, T.**, "Some observations on calender vibration and it's causes" paper presented on Sept. 14, 1962 at the Forest Products Research Laboratory, Stockholm
- ⁸ **Mumme, K.I.** and Tuttle, T.L., "Calender Vibration - A Simulation Study and a Cure", TAPPI, 52(7) July 1969, pp.1356-1362
- ⁹ **Parker, J.R.**, "Corrugation of calender rolls and the barring of newsprint", Paper Technology, 1965, 6(1), T1-T9
- ¹⁰ **Parker, J.R.**, Epton, J.B.A., "Analysis and control of calender barring", Pulp and Paper Canada, Vol. 76, No.. 10, October, 1975
- ¹¹ **Pye, I.T.**, Calender barring in newsprint, Pulp and Paper Mag. Can., 1963, 64(4) T194-T204
- ¹² **Wahlstrom, P.B.**, Larsson, K.O. and Asklof, C.A., "Calender barring, it's mechanism and possible elimination", Pulp and Paper Mag. Can., 1963, 64(4), T205
- ¹³ Discussion of 4 calender barring papers presented at the 49th Annual Meeting of Pulp and Paper Association of Canada, Papers by Pye, Wahlstrom, Cuffey and Howe

¹⁴ **Parker, J.R.**, Epton, J.B.A., "Analysis and control of calender barring", Pulp and Paper Canada, Vol. 76, No.. 10, October, 1975

¹⁵ **Brown, David L.**, "Grinding Dynamics", Doctor of Philosophy Dissertation, Department of Mechanical and Industrial Engineering, University of Cincinnati, 1980

¹⁶ **Browne, T.C.**, "Viscoelastic Properties of Paper in a Calender Nip", Doctor of Philosophy Dissertation, Department of Chemical Engineering, McGill University, Montreal, August, 1994